

# INSTRUCTIONS

## GENERAL RULES

1. Where specified, assemble and disassemble the shock absorption system using the **MARZOCCHI** special tools only.
2. On reassembling the suspension system, always use new seals.
3. Clean all metal parts with a special, preferably biodegradable solvent, such as trichloroethane or trichloroethylene.
4. Before reassembling, lubricate all parts in contact with each other using silicone fat spray or a specific oil for seals.
5. Always grease the lip seal rings before reassembling.
6. Use wrenches with metric size only. Wrenches with inch size might damage the fastening devices even when their size is similar to that of the wrenches in metric size.

## FAILURES, CAUSES AND REMEDIES

This paragraph reports some failures that may occur when using the fork. It also indicates possible causes and suggests a remedy. Always refer to this table before doing any repair work.

FAILURES	CAUSES	REMEDIES
Oil leaking through the top of the slider	<ol style="list-style-type: none"> <li>1. Oil seal is worn out</li> <li>2. Stanchion tube is scored</li> <li>3. Excessive dirt on slider oil seal</li> </ol>	<ol style="list-style-type: none"> <li>1. Replace oil seal</li> <li>2. Replace crown/stanchions assembly, oil seals and dust seals</li> <li>3. Clean the oil seal seat and replace oil seal and dust seal</li> </ol>
Oil leaking through the bottom of slider	O-ring seal on the cartridge nut is damaged	Replace the O-ring
Fork has not been used for some time and is locked out	Oil seals and dust seals tend to stick to stanchions	Raise dust seal and lubricate stanchion tube, dust seal and oil seal
Pressure drop	Cap valve damaged	Replace cap and/or valve
Excessive play of stanchions in the sliders	Pilot bushings worn out	Replace bushings
Fork rebounds too fast in any adjuster position	<ol style="list-style-type: none"> <li>1. Dirt inside fork legs</li> <li>2. RH stanchion cartridge is damaged</li> <li>3. LH stanchion cartridge is faulty</li> </ol>	<ol style="list-style-type: none"> <li>1. Clean carefully and change oil</li> <li>2. Replace RH stanchion cartridge</li> <li>3. Check LH stanchion cartridge</li> </ol>
Adjuster position does not affect fork operation	<ol style="list-style-type: none"> <li>1. Dirt inside legs</li> <li>2. Check cartridges operation</li> </ol>	<ol style="list-style-type: none"> <li>1. Clean carefully and change oil</li> <li>2. Replace and/or overhaul cartridges</li> </ol>

## RECOMMENDATIONS FOR MAINTENANCE

**MARZOCCHI** forks are based on advanced technology, supported by year-long experience in the field of professional mountain biking. In order to achieve best results, we recommend to check and clean the area below the dust seal and the stanchion tube after each use and lubricate with silicone oil.

In general, **MARZOCCHI** forks can offer top performance from the start. However, in some cases a short running-in period is required (5-10 hours) for inner adjustments. This running-in period will make fork life longer and ensure fork top performance over time.

**IMPORTANT:** change oil at least every 100 working hours and check pressure at least every 10 working hours.

**Polished** forks should be cleaned with bodywork **polish** at regular intervals in order to preserve their original finish.

## INSTALLATION

Installing the fork on a bicycle is a very delicate operation that should be carried out with extreme care. The installation should always be checked by one of our Technical Service Centers.



**WARNING:** steer tube/headset mounting and adjustment must be carried out in compliance with the headset manufacturer's instructions. Improper installation may jeopardize the safety of the rider.

To replace it, contact one of our Technical Service Centers with the required tools.



**WARNING:** in case of improper installation of the steer tube into the crown, the rider might lose control of his/her bicycle, thus jeopardizing his/her safety.

## DISC BRAKE SYSTEM ASSEMBLY



**WARNING:** if a disc brake system is installed on Marathon 29" forks featuring sliders glued to the arch, it is absolutely forbidden to remove the original bolts (**ref. B**). In case of a Marathon S fork it is allowed since arch-slider monolith is molded.

For Marathon 29", apart from retaining cantilever or linear pull brakes, they also secure the sliders legs to the slider monolith. If needed, the brake boss bolts can be replaced with buttonhead bolts (**ref. A**, part #532979QF).

Tighten the above-mentioned bolts to 10 Nm.

**IMPORTANT:** the bolt threads (**ref. A**) are treated to ensure a hydraulic seal. Never reuse the bolts once they have been removed.

Assembling the brake caliper onto the slider is a very delicate operation that should be carried out with extreme care.

Improper assembly might overstress the caliper supports which might break.

When installing the disc brake system, be sure to properly follow the instructions given by the manufacturer.

## ADJUSTMENTS

### FORK LEG PRESSURIZATION

Pump air through the valves to set COMPRESSION damping, as indicated in the figure. To change the pressure inside the fork legs, remove the protection cap (32) (LH fork leg), remove plug (21), turn knob (28) until you can see the valve under it (RH fork leg). Depressurize each leg by pushing lightly on valve pin. Fully tighten adapter fitting (D) supplied with the fork, on a MARZOCCHI pump (C). Screw fitting end – with O-ring (D1) on valve, and pressurize until the required value is reached. Unscrew the fitting/pump assembly and refit the cap (32).

**IMPORTANT:** inflate using the special MARZOCCHI pump with the proper pressure gauge. Use of improper tools or other procedures than specified ones might lead to improper inflating.

**NOTE:** in case of air leakages when adapter fitting (D) is fitted, ensure that the O-ring (D1) is not damaged.

### REBOUND ADJUSTMENT (r.h. fork leg)

The right fork leg is equipped with an Extension Control Cartridge adjuster knob (28) for REBOUND damping up to max. rebound damping - "Lock Out". Turning this adjuster into the cartridge rod, changes the hydraulic setting of the inner valves.

You can have three adjustments:

#### Pos. 1: "Lock Out"

Turn the knob completely counter-clockwise to obtain full ECC lockdown (maximum rebound damping) for steep climbs and road riding.

#### Pos. 2: "Intermediate rebound damping"

Turn the knob clockwise until hearing the first click. This medium position offers slow rebound damping for fast starts and rough climbs.

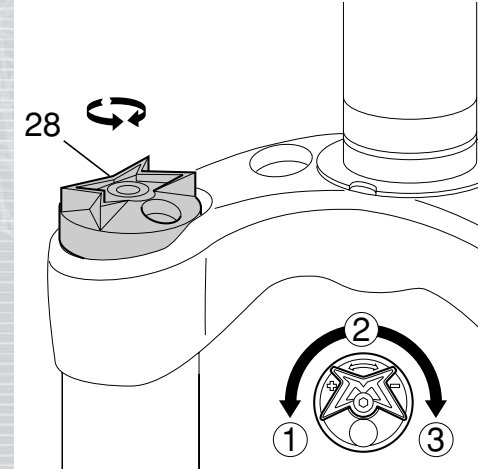
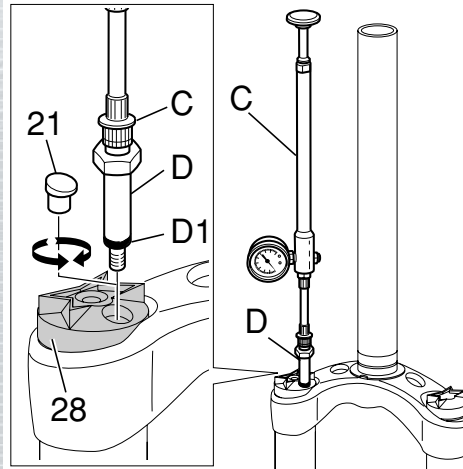
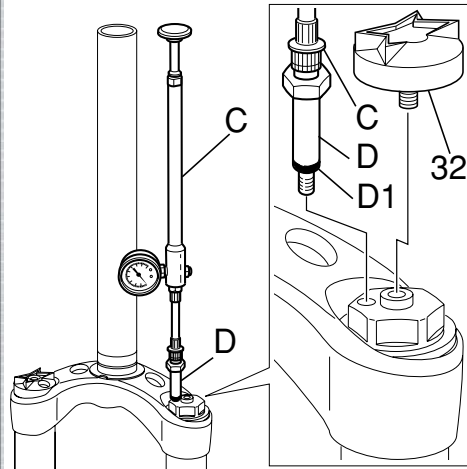

**Pos. 3: "Minimum rebound damping"**

Turn the knob completely clockwise until hearing the last click. In this position the fork will have fast rebound damping for downhilling.

**IMPORTANT:** do not force the adjuster knob (28) past its limit.

**NEGATIVE AIR CARTRIDGE ADJUSTMENT (LH fork leg - valve is located in the center of the cap)**

Pump air into the valve, as indicated, to set COMPRESSION damping. To change the pressure inside the fork legs, remove the protection cap (32) (LH fork leg) and depressurize the leg by pushing lightly on valve pin. Fully tighten adapter fitting (D), supplied with the fork, on MARZOCCHI pump (C). Screw fitting end -with O-ring (D1) on valve, and pressurize until the required value is reached. The higher the pressure in the LH cartridge, the more sensitive the fork will be and vice versa.

Unscrew the fitting/pump assembly and refit the cap (32).

**IMPORTANT:** inflate using the special MARZOCCHI pump with the proper pressure gauge. Use of improper tools or other procedures than specified ones might lead to improper inflating.

**NOTE:** in case of air leakage when adapter fitting (D) is installed, be sure that the O-ring (D1) is not damaged.

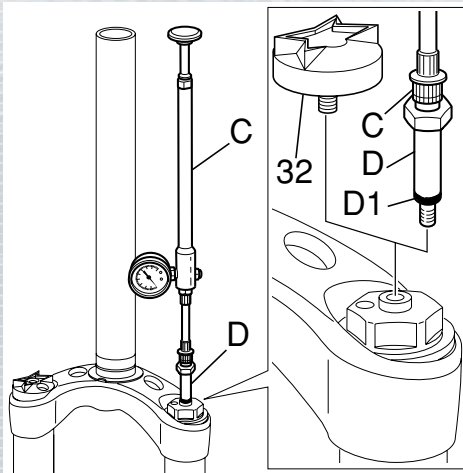
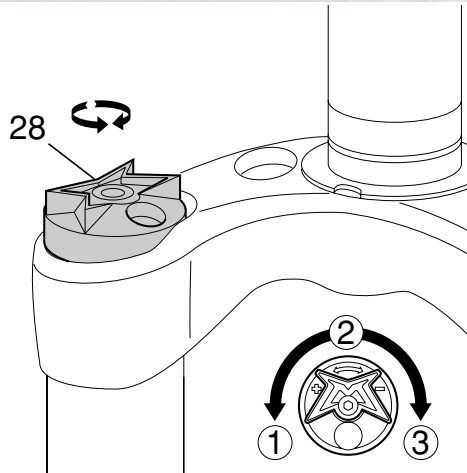

# DISASSEMBLY

## GENERAL

- The reference numbers given in this section relate to the components shown in the fork exploded view.
- Before starting any operation. please read the diagram below. It shows the quickest procedure and the exact disassembling sequence. Locate the part you need to remove in the diagram, then look at the arrows to determine which other parts you need to remove first.

## DISASSEMBLY DIAGRAM

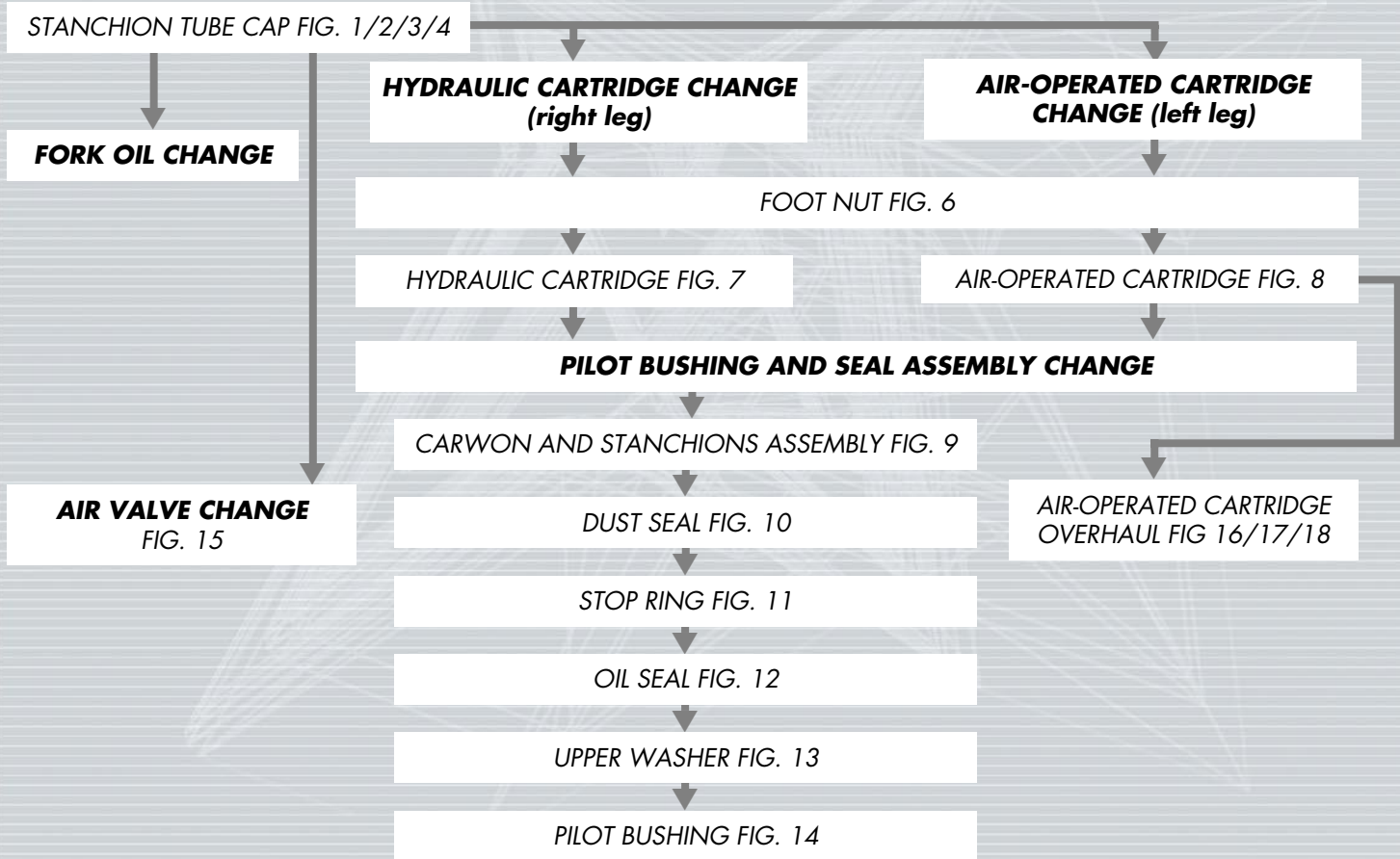

**REMOVING UPPER CAP**

**FIG. 1**

**(r.h. fork leg)**

Undo screw (29) with an Allen wrench and remove knob (28).

**(l.h. fork leg)**

Completely undo knob (32).

Depressurize each fork leg (see section ADJUSTMENT).

**FIG. 2 (only right leg)**

Remove the RH cartridge circlip (27) with a small screwdriver.

Remove and keep the pin (26) and counter spring (25).



**WARNING:** never use the fork without this component otherwise the hydraulic cartridge fitted to the slider bottom might slide out from the top cap and release the arch-slider monolith.

**FIG. 3**

Unscrew the caps (30) and (33) completely with O-ring (24) with a 21-mm socket wrench.

Remove the cap (30) from the right stanchion and from the hydraulic cartridge rod (5).

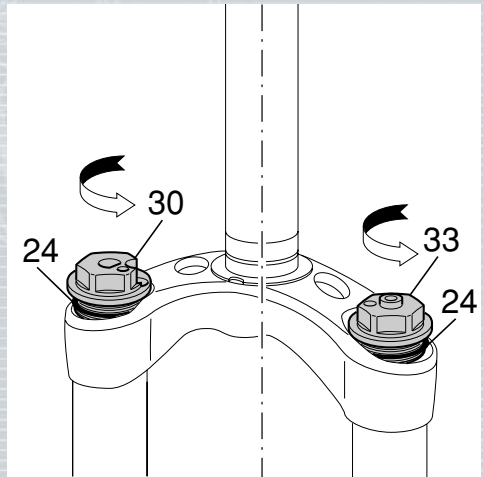
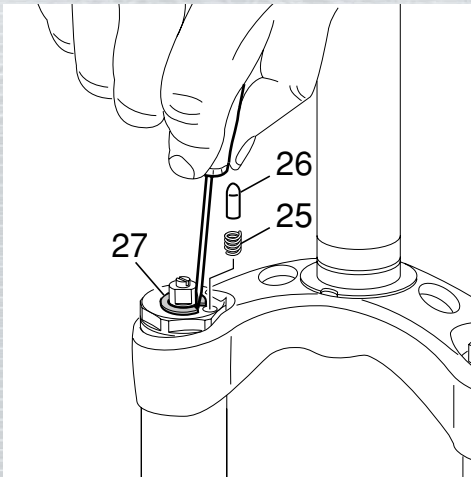
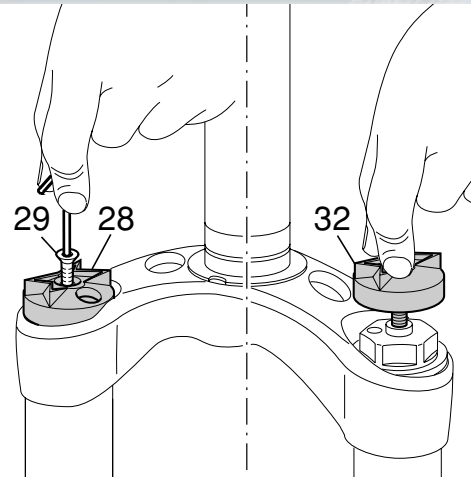

**FIG. 4 (only left leg)**

Lock the rod (16) and remove the cap (33) from hydraulic cartridge end (22). If this operation proves difficult, vice the rod with jaws (E) (see Fig. 28).

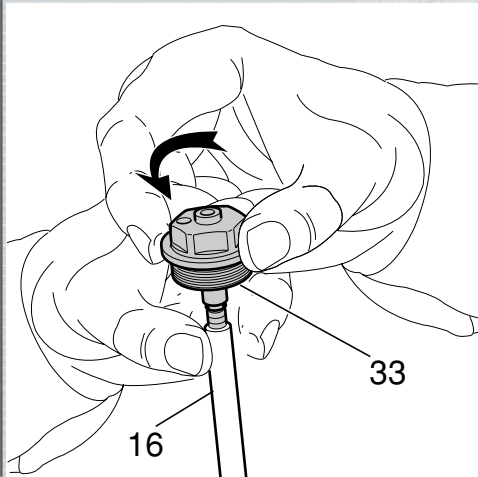

**FIG. 5**

Push the stanchions (23) into the sliders (3) and let all the oil drain out from the fork legs. Pump the stanchions several times to help oil drain off.



**WARNING:** dispose of exhausted oil in compliance with current laws.

To change the fork leg oil follow the procedure as described in section "REASSEMBLY" from Fig. 29 to Fig. 33.

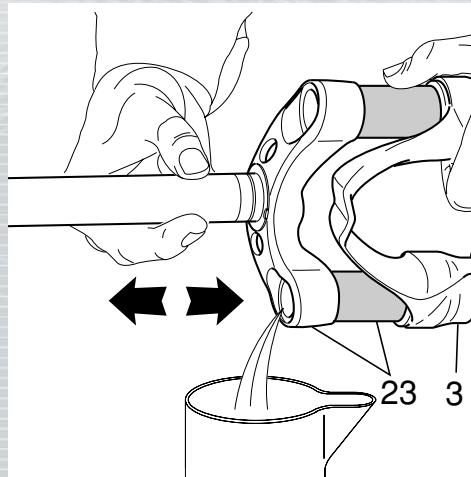

**REMOVING CARTRIDGES**

**FIG. 6**

Turn the fork leg upside-down and unscrew the foot nuts (2) by the use of a 15 mm socket wrench complete with O-Rings (1).

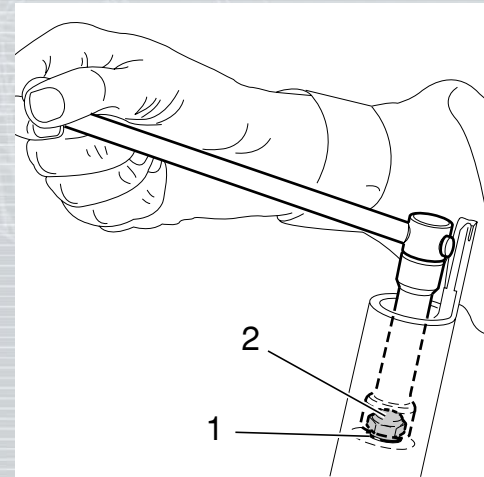



**FIG. 7 (only right leg)**

Pull the hydraulic cartridge (5) out of the R.H. stanchion tube.

Replace the whole hydraulic cartridge.

**FIG. 8 (only left leg)**

Pull the air-operated cartridge (22) out of the L.H. stanchion tube.

Replace the whole cartridge or overhaul as described in next paragraph.

**FIG. 9**

Withdraw the crown and stanchions assembly (23) from the sliders (3).

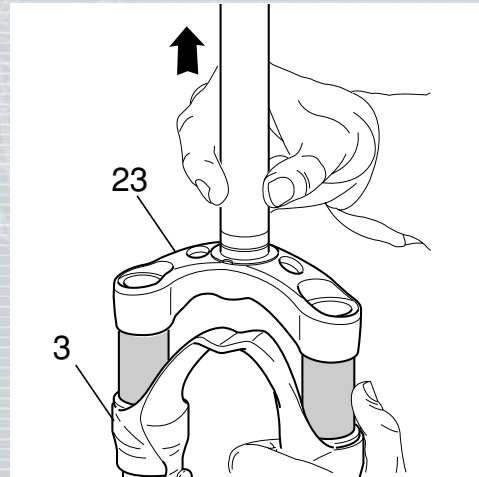
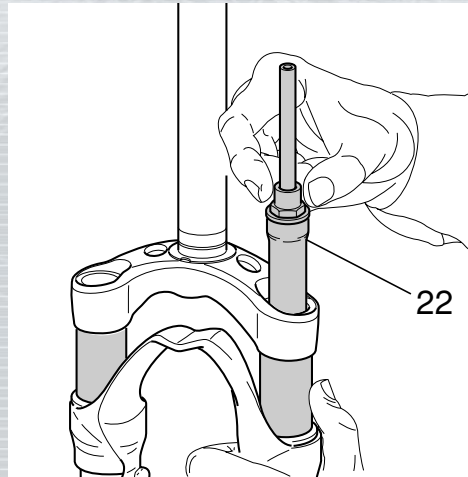
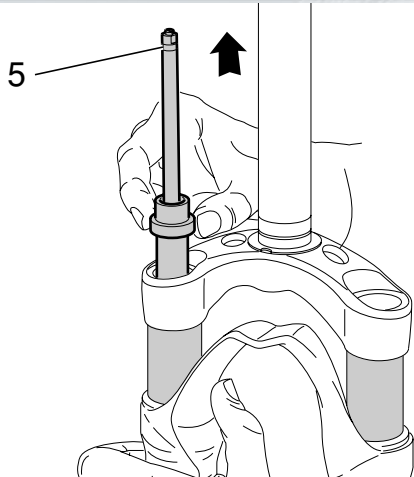

**REMOVING GUIDE BUSHING AND SEAL ASSEMBLY**

**FIG. 10**

Remove the dust seal (10) from the top of the sliders using a small screwdriver.

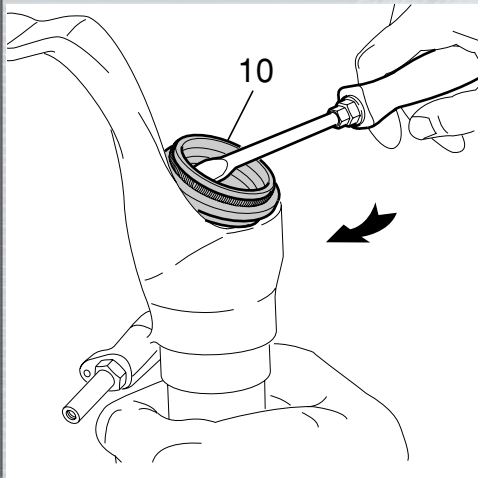

**FIG. 11**

Remove the stop ring (9) from the sliders by placing the screwdriver bit in one of the three openings on the stop ring.

**IMPORTANT:** when removing the stop ring, make sure not to damage slider inner seat.

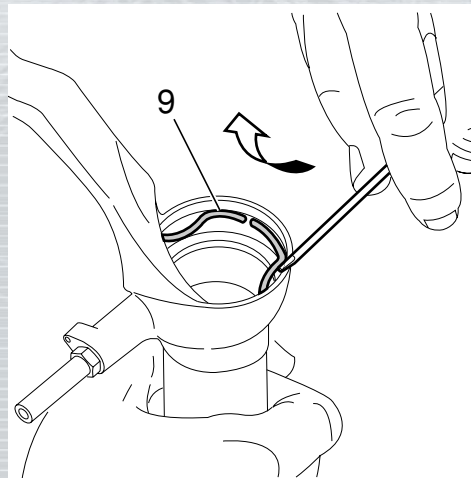

**FIG. 12**

Fit the slider protector (A) onto the slider and remove the oil seal (8) with the help of a large screwdriver.

**IMPORTANT:** when removing the oil seal, make sure not to damage slider inner seat. Once removed the oil seals should not be used again.

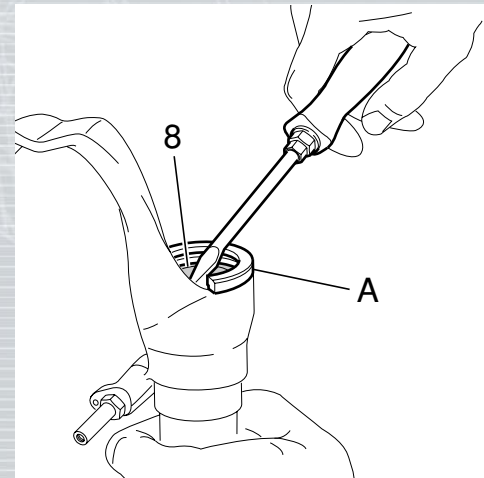

**FIG. 13**

Remove the upper washer (7) from the slider.



**FIG. 14**

Fit the bit of a small screwdriver into upper edge slot of the pilot bushing (6) and lift gently. Pull the bushing out of the slider and make all necessary changes.

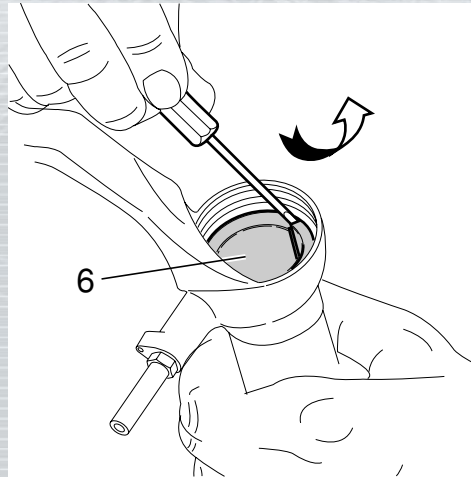

**REPLACING AIR VALVE**

**FIG. 15**

This operation can be performed when fork is fully assembled and fitted on bike, but only after draining inner pressure. If the air valve is disassembled with the fork removed, keep the fork vertical so as to avoid any oil leakage.

Remove protection cap (21) (only RH fork leg) and remove air valve (39) and O-ring (40) from the cap, with a standard valve wrench.

Check O-Ring and blow compressed air onto valve to eliminate possible clogging. Immediately replace the valve if it is damaged.

When reassembling, slightly lubricate the O-ring (40) and screw the air valve (39) until it stops without forcing. Then, refit the cap (21).

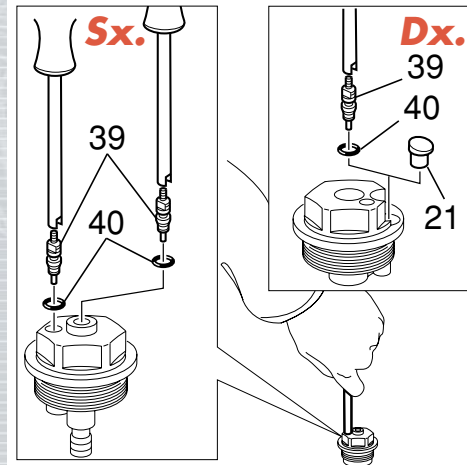

**AIR-OPERATED CARTRIDGE  
OVERHAUL**

**FIG. 16**

Hold cartridge (22) and undo the ring nut (14) and the O-ring (15) with a hex. wrench. Remove ring nut assembly (14) and rod (16), then remove rod (16) from ring nut (14).

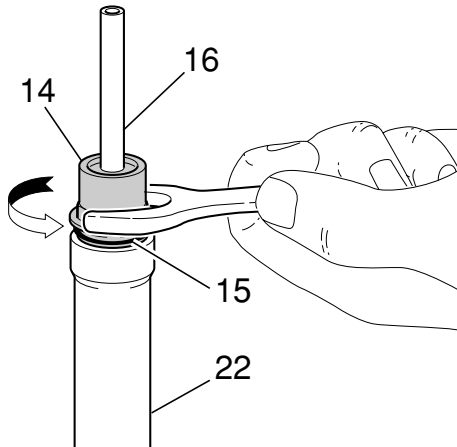

**FIG. 17**

With a small screwdriver, remove the seal (19) and the O-rings (18) from the rod body (16). Lubricate the O-rings before reassembly.

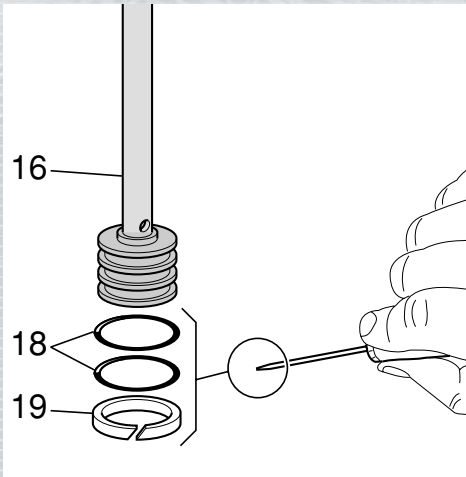

**REASSEMBLY**

**CAUTION:** before reassembling, all metal components should be washed carefully with inflammable, preferably biodegradable, solvent and dried with compressed air.

**RE-ASSEMBLING AIR-OPERATED CARTRIDGE**

**FIG. 18**

Insert the rod (16) and ring nut assembly (14) in the cartridge body (22) and tighten the ring nut to the specified torque. During this operation, be careful not to damage the O-rings (15) and (18).

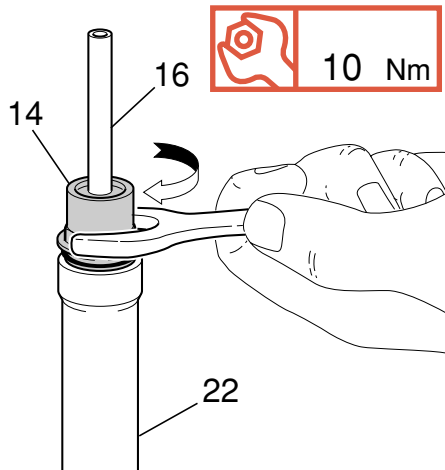

**PILOT BUSHING AND SEAL ASSEMBLY**

**FIG. 19**

Check that no dirt or debris is between slider and bushing. Insert the pilot bushing (6) into place so that it adheres to the slider.

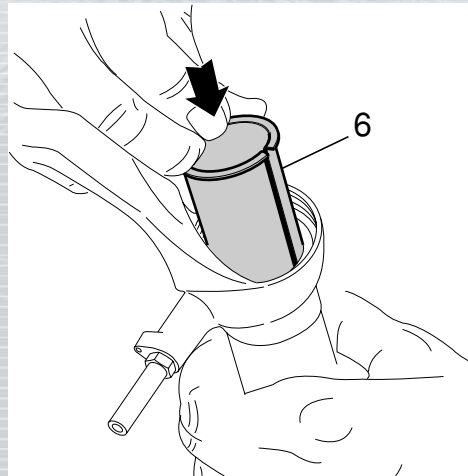

**FIG. 20**

Fit the upper washer (7) into the slider so that it touches the pilot bushing.

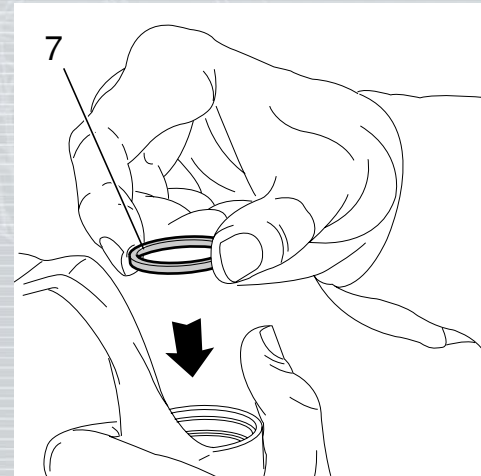

**FIG. 21**

Lubricate the oil seal (8) and place it onto the seal press (B) with the hollow side toward the slider.  
Press the oil seal until it touches the lower washer by using the above seal press.

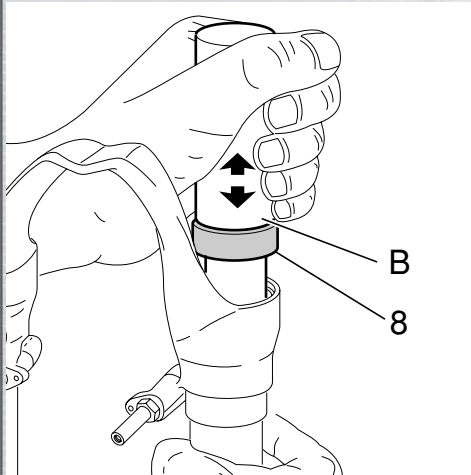

**FIG. 22**

Insert the stop ring (9) into the slider making sure it is properly seated into place.  
Use buffer (B) to properly seat the ring into the slider.

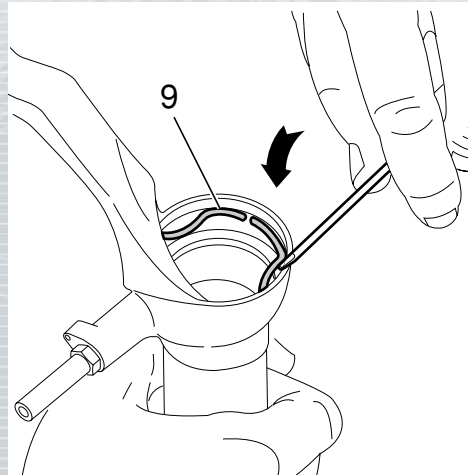

**FIG. 23**

Lubricate the dust seals (10) and fit them into the stanchions from the spring end.

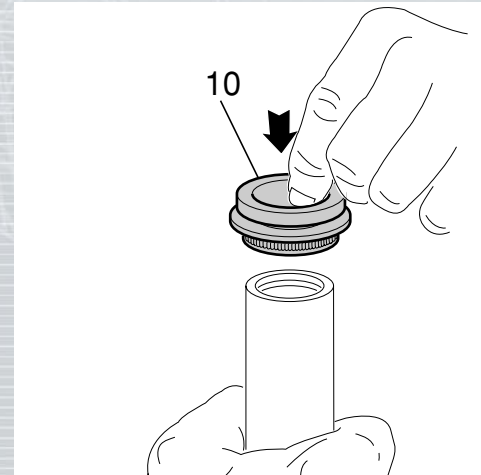

**CROWN AND STANCHIONS ASSEMBLY**

**FIG. 24**

Fit the crown and stanchions assembly (23) - with the dust seals in place - gently into the sliders seals.

**⚠ WARNING:** to avoid any damages to sealing surfaces, keep the stanchions duly lubricated and squared into the sliders.

Check to see that the stanchions slide unrestricted by cycling the fork up and down several times.

The tube should slide freely inside the seal assembly without any side play. In the event it is too hard or too soft, repeat the previous steps described above and check components to ensure they are not damaged. Seat the dust seals (10) on top of the sliders.

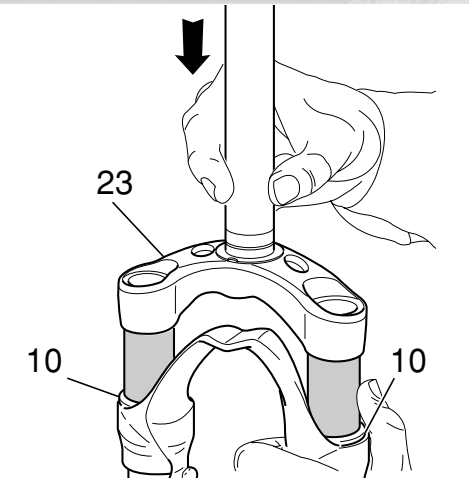

**REASSEMBLING CARTRIDGES**

**FIG. 25**

Push the stanchions up to slider bottom and slightly grease O-ring (4), then fit it on cartridge rod (5).

Fit the hydraulic cartridge (5) into the R.H. stanchion and push until it reaches the bottom.

Fit the air-operated cartridge (22) into the L.H. stanchion and push to the bottom.

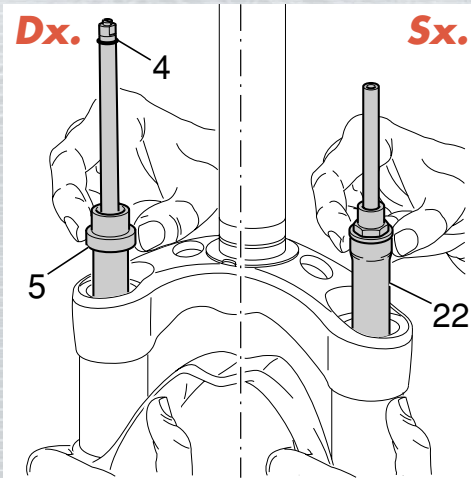
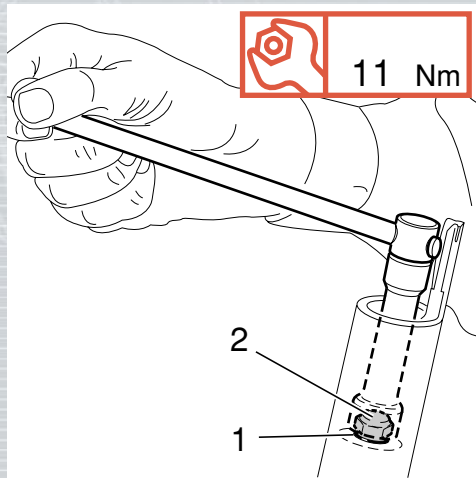

**FIG. 26**

Lubricate O-Rings (1) on the foot nuts (2) and screw them onto the cartridge (5) and (22) threaded ends.

Tighten to the specified torque.

Pump the stanchions up and down several times to check proper assembly.



**HOW TO FILL WITH OIL**

**FIG. 27**

Pour in the oil little by little when the stanchions are fully down and then stroke the crown up and down to cycle the oil and to remove any trapped air.

Check that the oil quantity (**Q**) inside the fork legs corresponds to the value indicated in the table.

Fork model	Travel (mm)	Leg	Q (cc)
Marathon S	80	Sx.	30
		Dx.	115
	100	Sx.	30
		Dx.	115
Marathon 29"	80	Sx.	30
		Dx.	115

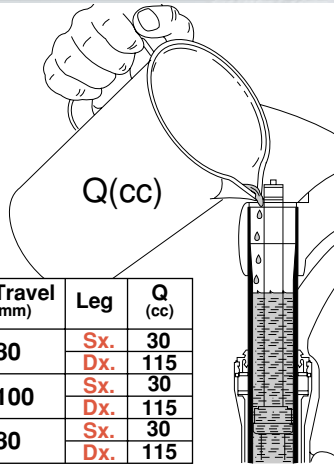

**REASSEMBLING UPPER CAP**

**FIG. 28 (l.h. cartridge only)**

Using pliers, (**F**) clamp the air-operated cartridge rod (**16**). Grease O-ring (**31**) and fully tighten the cap (**33**) on the rod end.

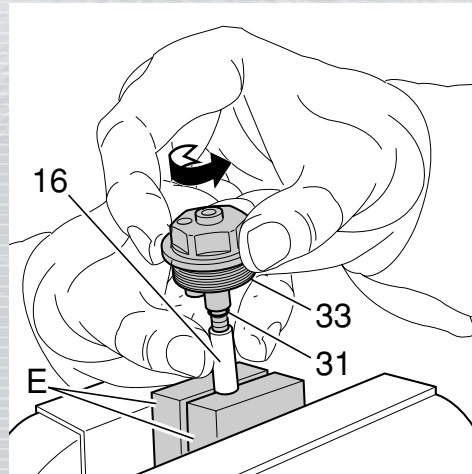
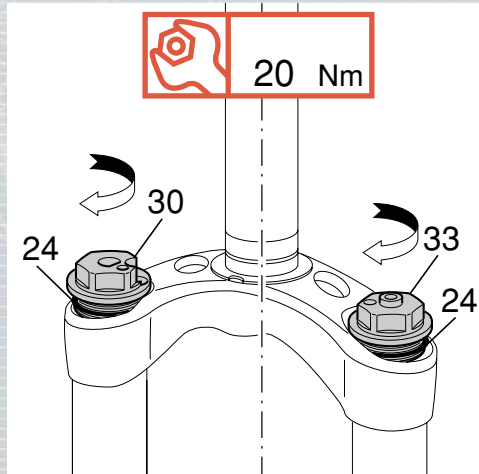

**FIG. 29**

Lubricate the O-rings (**24**) on the caps and lift the stanchions caps (**30**) and (**33**) by hand.

Tighten both caps to the recommended torque.

Inflate as described in ADJUSTMENT section.





**FIG. 30**

Fit circlip (27) of the adjustment knob support and check for the proper position in the seat. Fit also spring (25) and pin (26).

**⚠ WARNING:** never use the fork without this component otherwise the hydraulic cartridge fitted to the slider bottom might slide out from the top cap and release the arch-slider monolith.

**FIG. 31**

**(r.h. fork leg)**

Fit knob (28) and fully tighten the bolt (29) to the recommended torque.

**(l.h. fork leg)**

Screw knob (32) fully home.

