

marzocchi
WWW.MARZOCCHI.COM

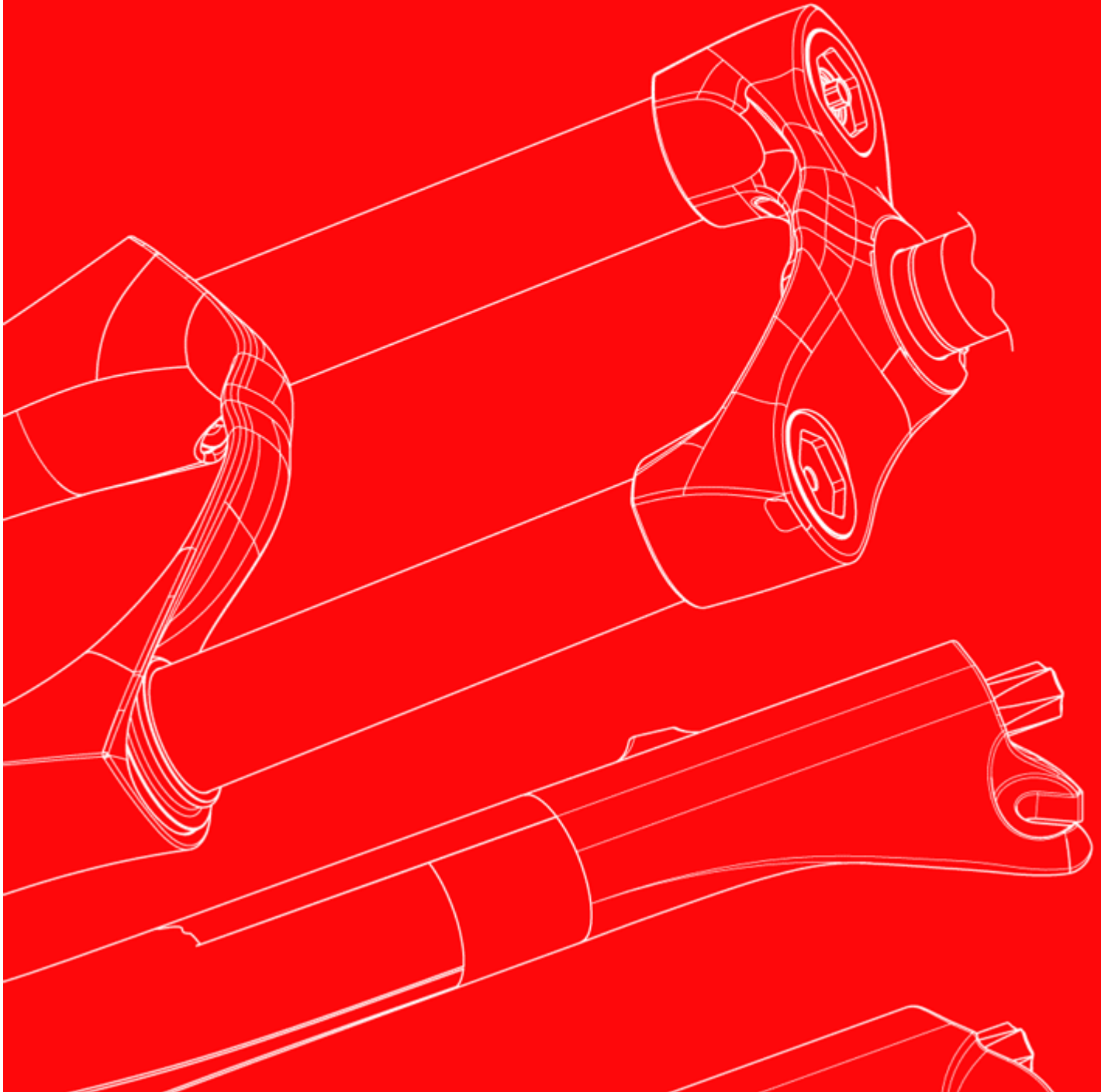

2005 - Shiver SC

Technical instructions

Exploded view - Shiver SC 100

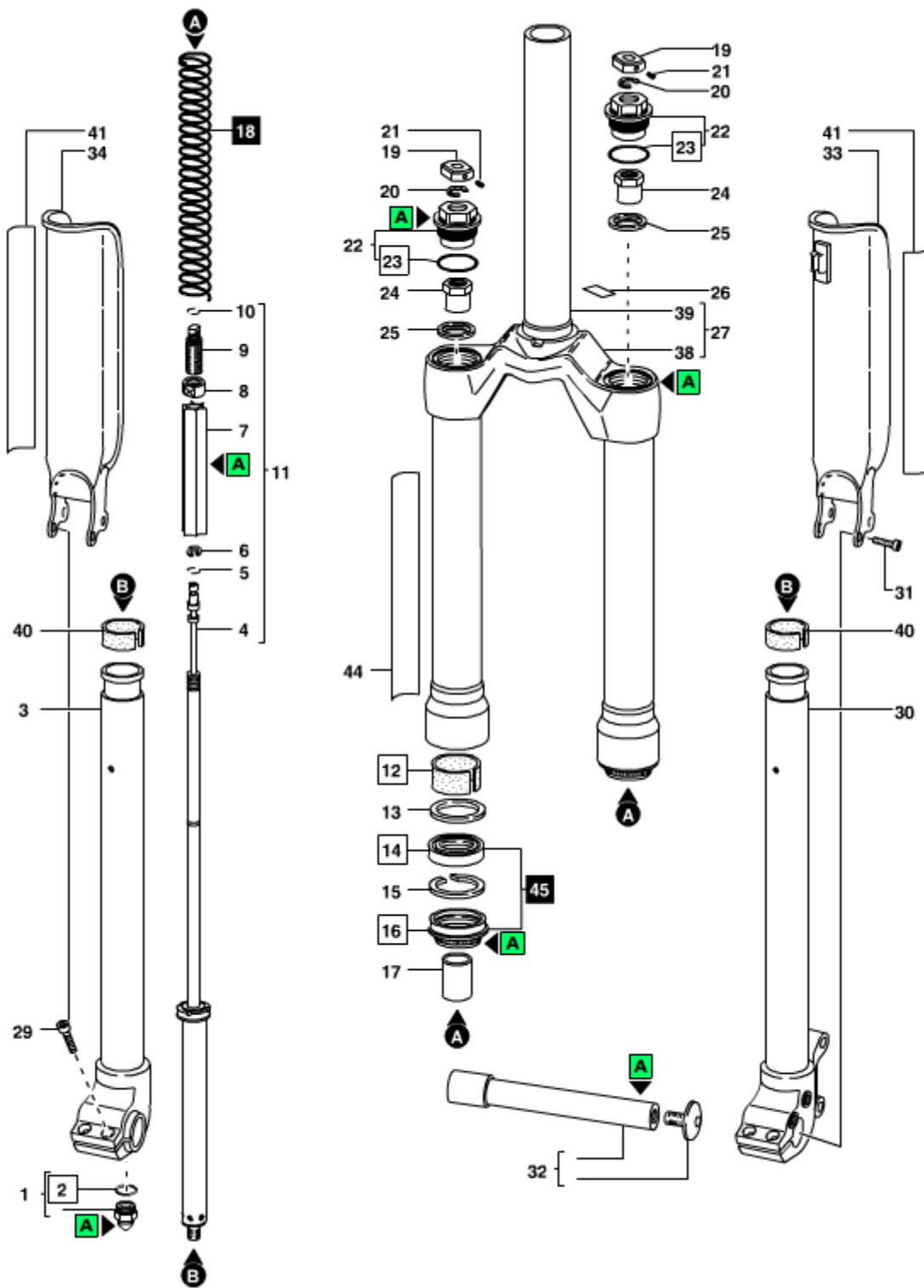

Rif. Code	Quantity
1 532756>A	2
2 528050	2
3 819134/R	1
4 5321086	2
5 528223	2
6 523286>A	2
7 5181090>A	1
8 521142IW>A	2
9 532810>A	2
10 528214	2
11 703705KM/C	2
12 538110	2
13 522288	2
14 528172NOK>B	2
15 523261	2
16 533301	2
17 5181186>A	2
18 5141164/C	1
19 549062LA	2
20 523254BZ	2
21 520263BZ	2
22 701197/C	2
23 528218	2
24 532980	2
25 522342	2
26 547636	2
27 818142/AC	1
28 520264AC	1
29 520023PN	4
30 819133/R	1
31 520317PN	6
32 850724	1
33 900731>A	1
34 900730>A	1
38 818142/R	1
39 508996CD/C	1
40 538111	2
41 547632	1
44 547621	1

Shiver SC 100 - Oil levels

Position	Oil type	Quantity (cc)
Right fork leg	SAE 7,5 - 550013	135
Left fork leg	SAE 7,5 - 550013	135

Spare part list - Shiver SC 100

Rif.	Code	Description	Q.ty in the model
1	532756>A	FOOT NUT GROUP	2
2	528050	O-RING	2
3	819134/R	R.H. DROP OUT+STANCHION TUBE	1
4	5321086	INNER SHAFT	2
5	528223	O-RING	2
6	523286>A	STOP RING	2
7	5181090>A	SPRIN GUIDE SLEEVE	1
8	521142IW>A	NUT	2
9	532810>A	ADJUSTER PIN	2
10	528214	O-RING	2
11	703705KM/C	CART.100 MM TRAV.SHIV.SC 2004	2
12	538110	BUSHING	2
13	522288	UPPER WASHER	2
14	528172NOK>B	OIL SEAL DIA.30	2
15	523261	STOP RING	2
16	533301	DUST SEAL DIA.30	2
17	5181186>A	PRELOAD SLEEVE 30MM LONG	2
18	5141164/C	SPRING KIT RED K=3,9 C.130	1
19	549062LA	PRE LOAD KNOB- BLACK	2
20	523254BZ	STOP RING	2
21	520263BZ	ALLEN BOLT	2
22	701197/C	PLUG	2
23	528218	O-RING	2
24	532980	EXTERNAL PRELOAD ADJUSTER	2
25	522342	WASHER	2
26	547636 (replaces 547585)	REBOUND ADJUSTER STICKER 05	2
27	818142/AC	CROWN+OUTER TUBE+STEEL STEM	1
28	520264AC	IN CAP AXLE	1
29	520023PN	SCREW TCE M6X20	4
30	819133/R	L.H.DROP OUT + STANCHION TUBE	1
31	520317PN	SCREW	6
32	850724	AXLE KIT	1
33	900731>A	LH PLASTIC SHIVER SC GUARD	1
34	900730>A	RH PLASTIC SHIVER SC GUARD	1
38	818142/R	CROWN+OUTER TUBES	1
39	508996CD/C	REINFORCED STEEL STEM 1 1/8	1
40	538111	BUSHING	2
41	547632	RH+LH GUARD LABELS SHIVER SC05	1
44	547621	RH+LH LABELS SHIVER SC 05	1

Technical characteristics: Technical characteristics

Single-crown fork with \varnothing 30mm reverse legs.

Available travels: 100 mm.

Right fork leg damping element: spring with preload mechanical adjustment.

Left fork leg damping element: spring with preload mechanical adjustment.

Right fork leg damping system: HSCV cartridge with external rebound adjustment.

Left fork leg damping system: HSCV cartridge with external rebound adjustment.

The sliders are pressed into the crown.

The guide of the stanchion tubes inside the sliders has special long-life bushes that are easy to reach.

Lubrication and cooling of the parts subject to friction with a specially formulated oil.

Steer tube: reinforced steel, 1-1/8", threadless.

Crown: BAM® aluminium alloy forged and CNC machined.

Top crown: aluminium alloy forged and CNC machined.

Stanchions: anodised aluminium.

Dropouts: aluminium alloy, CNC machined, fixed solidly to the stanchion tubes.

Sliding bushings: made of friction-free and wear-free material.

Springs: constant pitch.

Seals: computer designed oil seals that guarantee maximum seal in any condition.

Oil: specially formulated oil that prevents foam and keeps the viscosity unchanged while offering high performance; free from static friction.

Dropout type: motorcycle type wheel axle support, with 20mm advanced axle and double screw locking system on both dropouts (specific wheel axle, supplied).

Disk brake mount: XC International Standard for 6" disk (fitting the special adapter supplied by the brake system manufacturer you can install the 8" disk).

Max wheel size: 2.8" x 26".

Leg guards: available as option.

BAM® : Bomber Aerospace Material: special alloy coming from the aerospace industry.

Warnings: Instructions for use

MARZOCCHI forks are based on an advanced technology coming from the company's years long experience in the professional mountain bike industry.

For the best results, we recommend inspecting and cleaning the area below the dust seal and the stanchion tube after every use and lubricating the parts with some silicone oil.

MARZOCCHI forks usually offer the best performances since the very first rides. Notwithstanding this, a short running-in period may be necessary (5-10 hours) to adjust the internal couplings. This precaution will lengthen your fork's life and guarantee its best performances.

We recommend changing the oil at least every 100 hours.

The forks with a polished finish must be treated periodically with polishing paste to keep the exterior shining like new.

Warnings: General safety rules

After disassembling the forks, always use new, original Marzocchi seals when reassembling.

To tighten two bolts or nuts that are near each other, always follow the sequence 1-2-1, and tighten to the required tightening torque.

Before reassembly, wash all new and old components and dry them with some compressed air, making sure there are neither breaks nor burrs.

Never use flammable or corrosive solvents when cleaning the forks, as these could damage the fork's seals. If you must use a solvent, use biodegradable detergents that are not corrosive, non-flammable, or have a high flash point.

Before reassembling, always lubricate those components that are in contact with the fork's oil.

If you are planning not to use your forks for a long period of time, always lubricate those components that are in contact with the fork's oil.

Always collect and keep any lubricants, solvents, or detergents, which are not completely biodegradable in the environment. These materials should be kept in appropriate containers, and disposed of according to local laws.

Always grease the seal lips before reassembling.

All of the components of Marzocchi forks require the use of metric tools. Use only metric tools. Imperial (US) tools may have similar sizes, but can damage the bolts, making them impossible to loosen or tighten.

When using a screwdriver to assemble or disassemble metal stop rings, O-rings, sliding bushings, or seal segments, avoid scratching or cutting the components with the screwdriver tip.

Do not carry out any maintenance and / or adjustment operations that are not explained in this manual.

Only use original Marzocchi spare parts.

Before servicing the fork, we recommend washing the fork thoroughly.

Work in a clean, organized, and well-lit place. If possible, avoid servicing your forks outdoors.

Carefully check to see that your work area is free of dust and metal shavings from any component of the forks.

Never modify your fork in any way.

Warnings: Fitting the fork onto the frame

The fork is supplied with "A-Head Set" steer tube to be cut to size according to frame being used.

Fitting the fork onto the bike frame is a very delicate operation that must be carried out at one of our service centres only.

The assembling on the frame and the adjustment of the steer tube must be carried out following the instructions of the steering set manufacturer.

A wrong installation can be dangerous for the rider.

Marzocchi does not guarantee the assembly and accepts no liability for damage and/or accidents arising from a wrong installation.

The steer tube must be pressed into the crown; its replacement must be carried out by one of our service centres using the adequate tools.

A wrong installation of the steer tube into the crown may cause the rider to lose the control of the bike and lead to serious personal injury.

Warnings: Installing the disk brake

Installing the brake system is a delicate and critical operation that must be carried out by an authorized Marzocchi Service Center.

Marzocchi is not responsible for the installation and accepts no liability for damage and/or accidents arising from this operation.

Improper installation of a disk brake system can overstress the caliper mountings, which may cause the caliper mountings to break, resulting in loss of control of the bicycle, an accident, personal injury, or death. Be sure that the brake system installation is also performed in strict compliance with the instructions provided by the brake system manufacturer.

Improper installation can result in an accident, personal injury, or death.

Use only brake systems that comply with the forks specifications.

The brake cable must never touch the crown and stanchions.

Warnings: Assembling the wheel

For a correct operation of the fork, install the wheel as explained below:

Insert the wheel axle (1) through the right dropout, the wheel and the left dropout.

With the 6mm Allen wrench, tighten the left screw (2) to the recommended tightening torque (**15 Nm ± 1**).

Check the correct fork-wheel alignment by fully compressing the fork a few times. The wheel should not come into contact with any parts of the fork.

Lift the front wheel above the ground; turn the wheel a few times to verify the correct alignment with the disk brake. Read the instructions of the brake system manufacturer for the correct specifications.

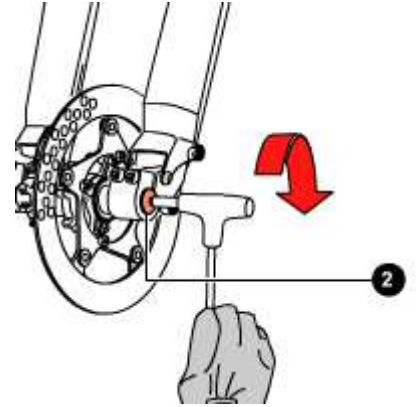
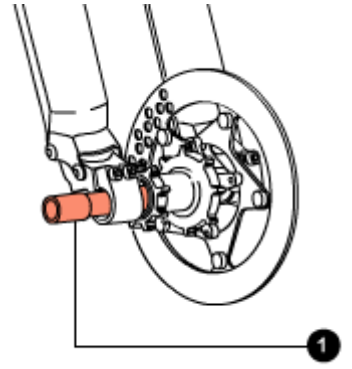

With a 5mm Allen wrench, tighten the screws (3) on both dropouts to the recommended tightening torque (**10 Nm ± 1**) following the sequence 1-2-1.

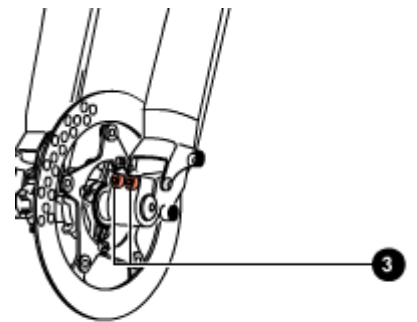
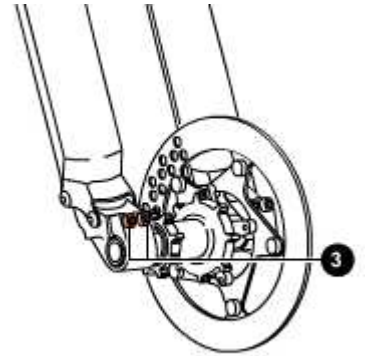

Dismantling: Removing the top caps

Put the fork in the vice in vertical position, fixing it by the dropouts.

With a 1.5mm Allen wrench loosen the grub screw (4) and remove the adjusting knob (5).

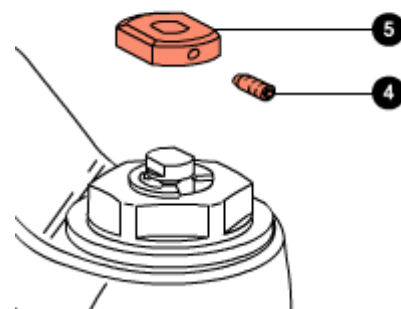

Remove the stop ring (8).

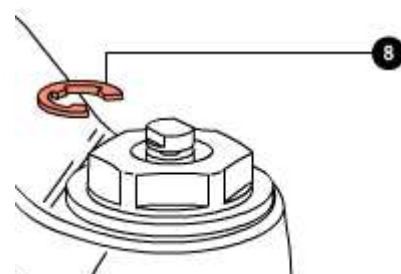

With a 21mm socket spanner fully unscrew lock cap (1).
Remove the lock cap (1).

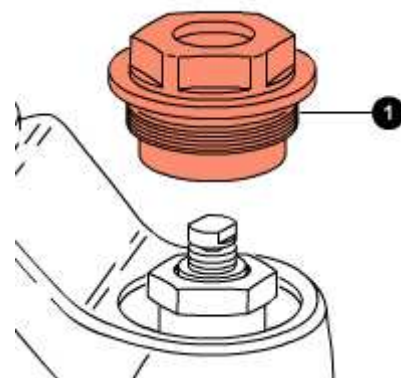

Remove pusher (7) from the threaded pin (6) of the pumping element taking into account that these two parts have a left-hand threading.

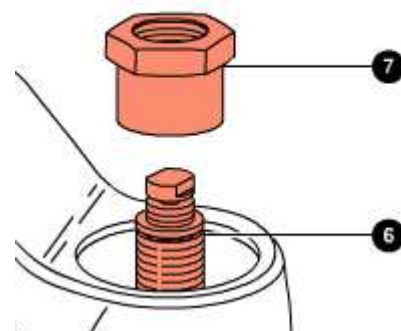

Dismantling: Draining the oil

Remove washer (1), the preload tube (2) and spring (3) from both legs.

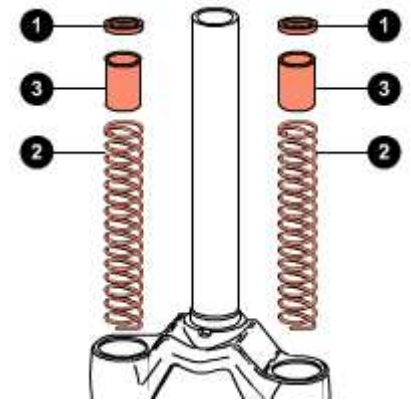

Free the fork from the vice and tip it into a container of a suitable size to drain the oil; compress the fork a few times to help the oil flow out.

Do not pour used oils on the ground.

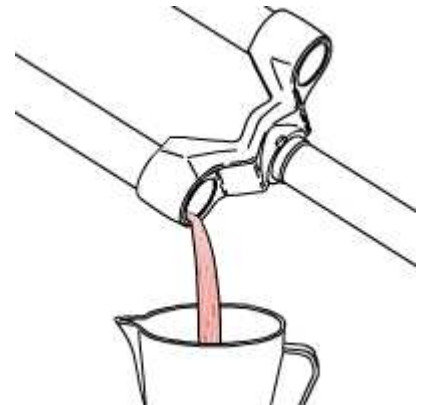

Dismantling: Dismantling the hydraulic cartridge

Proceed as follows for both legs:

Turn the fork leg upside down and loosen the bottom nuts (8) with a 15mm socket spanner.

Pull out bottom nuts (8) complete with O-rings (9).

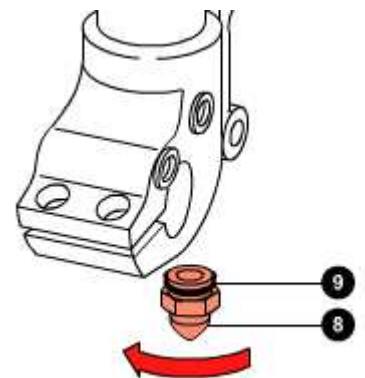

Pull the complete cartridges (5) off the fork legs.

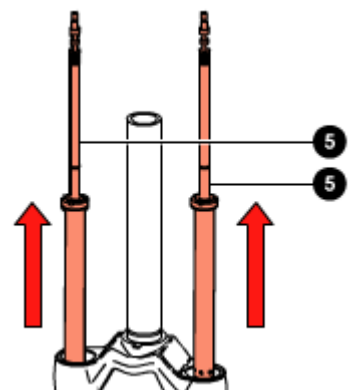

Holding locknut (1) with a 10mm fixed spanner, loosen the threaded pin (2) using a 7.5mm fixed spanner.

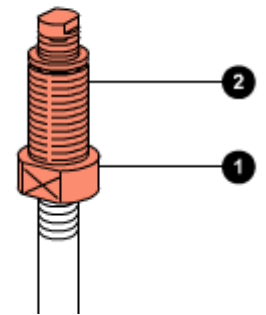

Remove the threaded pin (2) and locknut (1).

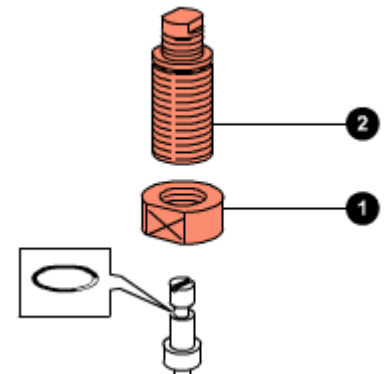

Remove the spring guide tube (7).

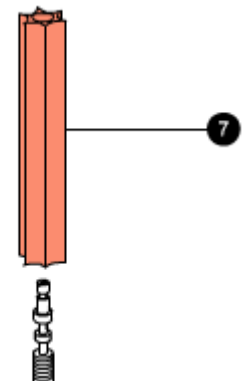

The HSCV cartridges (5) are sealed through machining and cannot be overhauled. In the case of faults or a malfunctioning, they must be replaced.

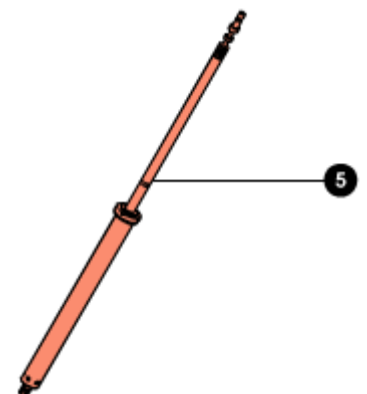

Dismantling: Breaking down stanchion tube, slider and removing the sealing rings

This operation must be done only after having drained all of the oil out of the slider.

Prize the dust seal (1) off its seat with a small flat-tip screwdriver.

Take great care not to damage the internal surfaces of the slider while removing the dust seal.

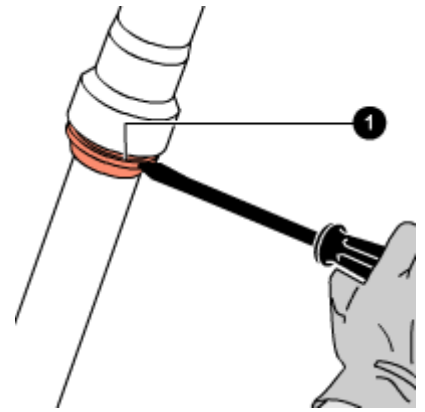

With the same screwdriver, prize off the metal stop ring (2).

Take great care not to damage the internal surfaces of the slider while removing the stop ring.

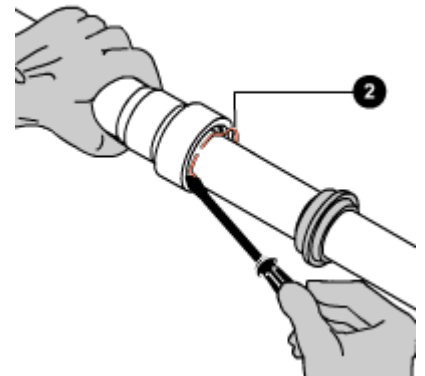

Pull stanchion (3) out of slider (4); to separate these two elements you will have to pull hard. With this operation the sealing ring (5), the spring cup (6) and the bottom guide bush (7) will be removed from the slider.

Remove the top guide bush (8) by hand. If this operation is difficult by hand, use a flat-tip screwdriver in the bush groove.

Remove the bottom guide bush (7), the spring cup (6), the sealing ring (5), the stop ring (2) and the dust seal (1) from the stanchion.

The old sealing rings and the dust seals must not be used again.

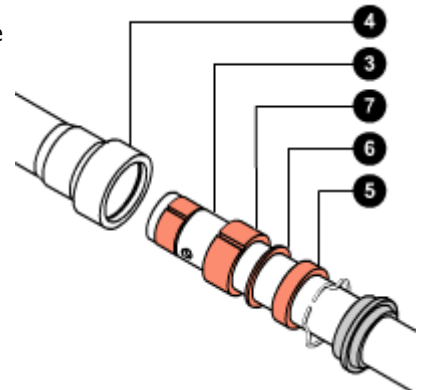

Remove the top guide bush (8) by hand. If this operation is difficult by hand, use a flat-tip screwdriver in the bush groove.

Remove the bottom guide bush (7), the spring cup (6), the sealing ring (5), the stop ring (2) and the dust seal (1) from the stanchion.

The old sealing rings and dust seals must not be used again.

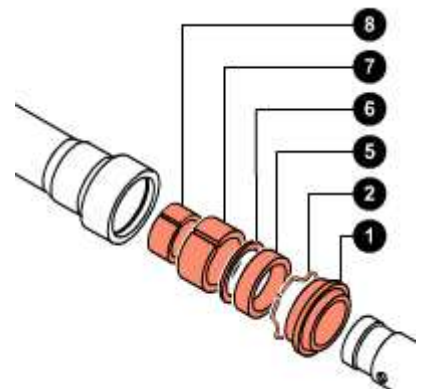

Assembling: Reassembling stanchion tube, slider and sealing rings

The old sealing rings and dust seals must not be used again.

Before reassembling, check the conditions of the guide bushes. Replace, if they are scratched or grooved. Check the wearproof coating of the guide bushes which must be in a good condition.

Apply some adhesive tape to the end of the stanchion so that it covers the seat of the top bush.
Smear the dust seal and the sealing ring with some grease.

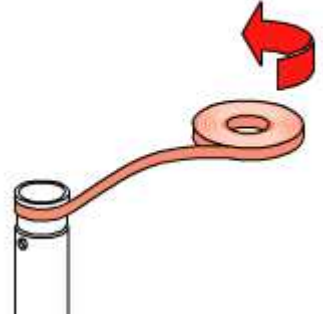

Insert the following components in the stanchion tube in this order: dust seal (1), stop ring (2), sealing ring (5), spring cup (6) and bottom guide bush (7).

Remove the adhesive tape from the end of the stanchion tube, cleaning any traces of adhesive left on the fork.

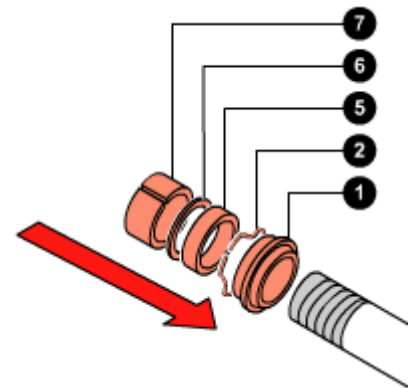

Insert the top guide bush (8) by hand.

If this operation is difficult by hand, use a flat-tip screwdriver in the bush groove.

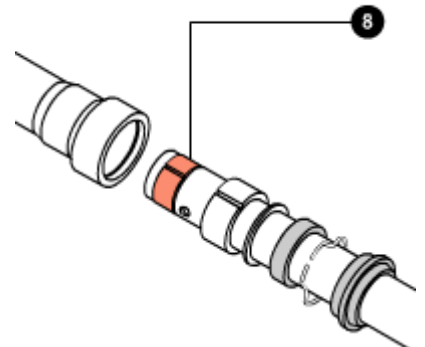

Gently introduce the stanchion into the slider, being very careful not to damage the top guide bush.
Guide the bottom guide bush until it comes in contact with the slider, the spring cup and the sealing ring.
Mount introducer (A) on the stanchion and use this, by pushing on sealing ring (5), to insert the bottom guide bush, the spring cup and the sealing ring.

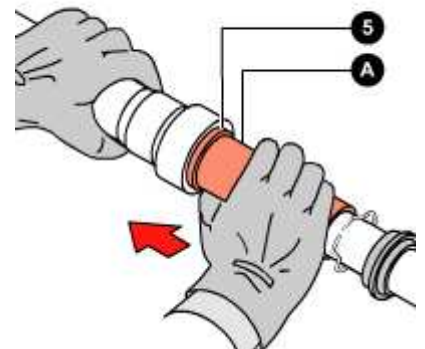

Mount stop ring (2) using a small flat-tip screwdriver checking that it fits perfectly into its groove and being very careful not to scratch the stanchion tube.

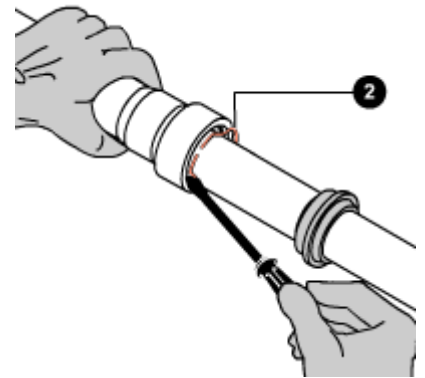

Re-assemble the dust seal (1) in its seat, pressing it home with your hands.

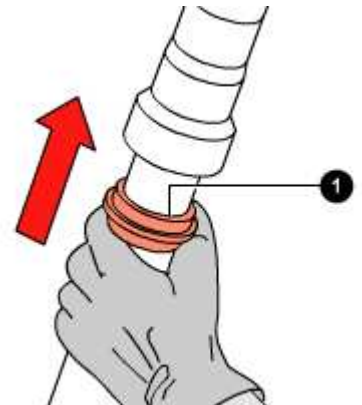

Assembling:

During the assembly of the pumping unit, strictly obey the instructions below.

Do not, at any times, reverse the position of the pumping elements in the fork legs (if you are unsure about anything, please refer to the relevant exploded view).

Assembling: Assembling the cartridge

Proceed as follows for both legs:

Insert the spring guide tube (7) in the cartridge rod.

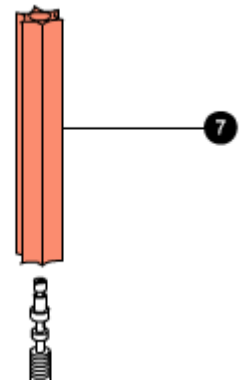

Tighten locknut (1) on the cartridge rod.

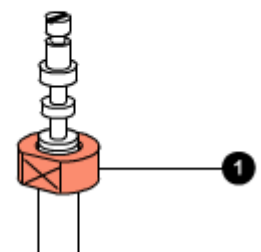

Tighten the threaded pin (2) on the cartridge rod being careful not to damage the O-ring.

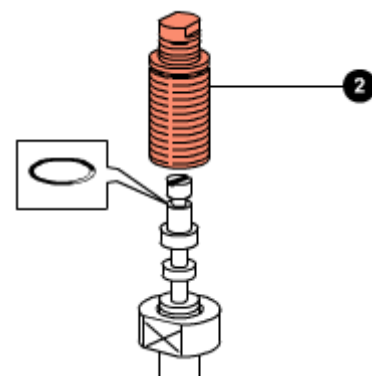

With the 10mm and 7.5mm spanners, tighten locknut (1) on the threaded pin (2) to the recommended tightening torque (**6 Nm ± 1**).

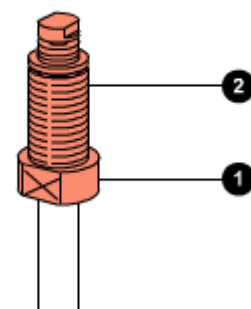

Insert the complete cartridge (5).

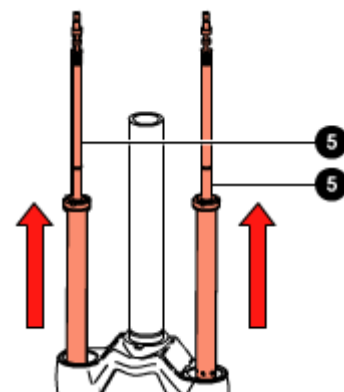

Using a 15mm socket spanner, tighten the bottom nuts (8) with O-rings (9) to the recommended tightening torque (**10 Nm ± 1**).

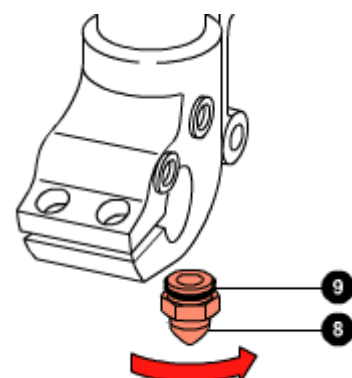

Assembling: Filling with oil

Block the fork in the vice, in perfectly vertical position.

Fully lower the sliders and the cartridges on the stanchion tubes.

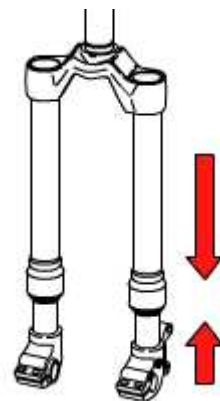

In a graduated recipient, prepare the quantity of oil to pour into the fork leg (see table).
 Pour roughly 1/3 of the oil required into each stanchion, then pump the fork a few times to eliminate any traces of air.
 Pour the rest of oil in.



A lower or higher volume or a type of oil other than the one recommended can change the behaviour of the fork in every phase.

Lift the sliders with cartridges off the stanchion tubes.

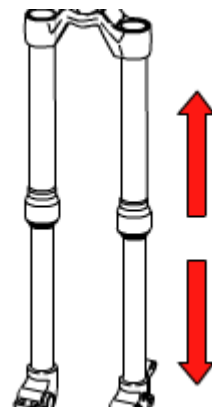

Insert spring (3), the preload tube (2) and washer (1) in both legs.

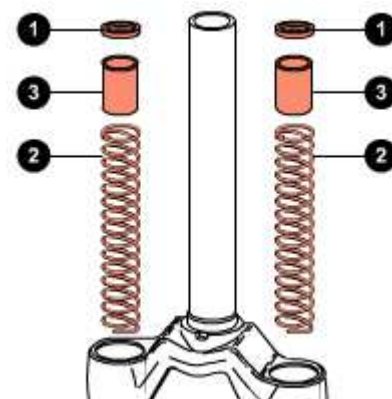

Assembling: Mounting the top caps

Put the fork in the vice in vertical position, fixing it by the dropouts.

Tighten pusher (7) on the threaded pin (6). In this way, the stop ring groove on the same pin will be visible once the cap has been assembled.

The pusher and the threaded pin have a left-hand threading; therefore they shall be screwed down turning the pusher counter-clockwise.

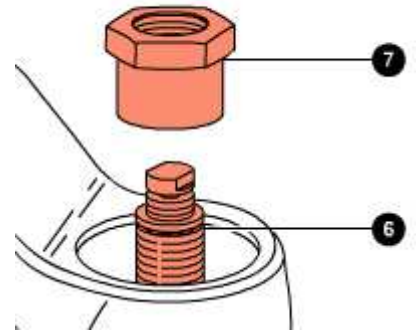

Fit lock cap (1) and, with a 21mm socket spanner, tighten to the recommended tightening torque (**10 Nm ± 1**).

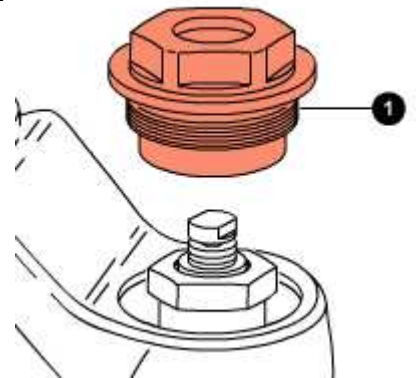

Mount the stop ring (8).

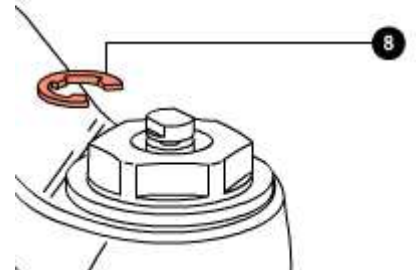

Mount the adjusting knob (5) and, with a 1.5mm Allen wrench, tighten the grub screw (4) to the recommended tightening torque (**1.5 Nm ± 2**).

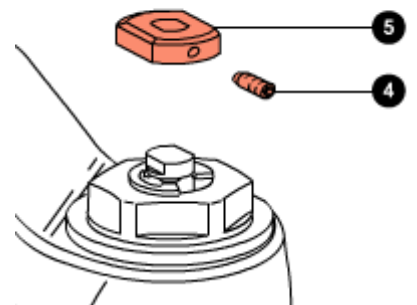

Setting: General rules for calibration

By carefully calibrating the damping system you can get the maximum performance out of the same.

This paragraph indicates the sequence of operations to perform to set up the Marzocchi forks correctly.

In order to find the best settings for you, you will need to try several times to understand where and how to make adjustments. When doing so, please ride in an open area, free from traffic, obstacles and other hazards.

The optimal setting is influenced by the geometry of the frame of the mountain bike, the weight of the cyclist, the type of terrain the bike will be used on and the type of obstacles you have to deal with, but also by subjective factors associated with your riding style; therefore it is impossible to provide objective data on the desired settings.

Nevertheless by carefully following the instructions below you will soon be able to find the optimal setting for you.

The shock absorber must be calibrated simply by using one adjuster at a time, following the order explained, noting the operations and any result step-by-step.

During setting don't force the adjusters beyond their limit of travel and don't exceed the max recommended air pressure.

To keep the pressure inside the fork's legs, only use the special MARZOCCHI pump with pressure gauge.

The use of any other pump can compromise the inflating operation and cause malfunction or damage to the fork, resulting in an accident, personal injury or death.

Once the correct setting has been found, we recommend noting the number of clicks or turns of the adjuster with respect to the "fully closed" position (adjuster fully clockwise) for a faster re-setting of your fork in case of need.

Setting: SAG

SAG means the fork bottoming under the biker's weight.

How to measure the SAG:

Follow these simple steps to measure the SAG.

On the leg portion of the fork, measure the distance between the lower crown and the dust seal (see Picture **A**). Note this value as "**H1**".

While sitting on the bike, repeat the measurement (see picture **B**). Note this value as "**H2**".

SAG = H1 - H2

How to find the best percent SAG:

The best percent SAG is 15-20% for Cross-country and All Mountain forks and 25-30% for Freeride and Downhill forks.

In order to calculate the best SAG for your own fork, you will need to make the following calculation:

SAG = T x S (**T** = total travel; **S** = suggested sinking percentage).

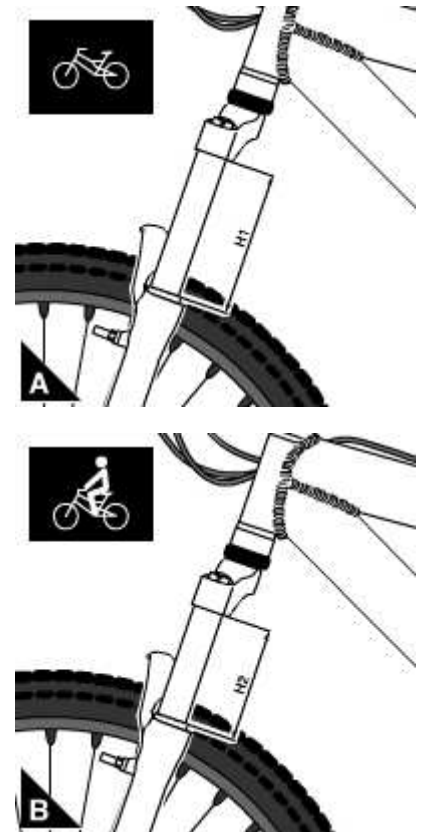

Setting: Spring preload

For both fork legs:

The optimal spring preloading is the one that lets you obtain the desired SAG under the biker's weight.

The forks are factory-set to the minimum preload, say with the adjuster fully turned counter-clockwise.

In this configuration, the spring is slightly preloaded to counteract static loads.

Turning adjuster (**A**) clockwise increases the spring preload.

Turning adjuster (**A**) counter-clockwise decreases the spring preload.

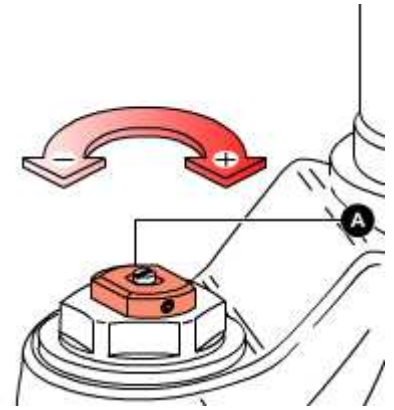

Do not force the adjuster beyond its limit of travel.

Setting: Rebound adjustment

Right fork leg:

With the rebound adjuster you can control the return speed of the fork after compression.

The right rebound speed setting makes the bike stable letting it follow the variations in the terrain and any obstacles.

If the fork setting is too reactive this will make the rear suspension instable and the mountain bike will have a tendency to snake. A too slow setting however will cause problems when dealing with multiple obstacles where the suspension can't return to its fully extended position fast enough between one obstacle and the next.

Turning adjuster **(A)** clockwise increases the hydraulic damping making the fork slower during the rebound phase.

Turning adjuster **(A)** counter-clockwise decreases the hydraulic damping making the fork more reactive during the rebound phase.

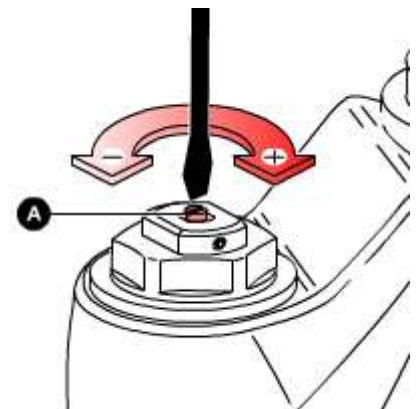

Do not force the adjuster beyond its limit of travel.

Tightening torques

Components	Tightening torque (Nm)
Fork leg top caps	10±1
Preload knob locking grub screws	1,5±0,2
Preload knob locknut	6±1
Pumping element/cartridge bottom nuts	10±1
Wheel axle Allen screws	10±1
Wheel axle screws	15±1

Shiver SC 100 - Oil levels

Position	Oil type	Quantity (cc)
Right fork leg	SAE 7,5 - 550013	135
Left fork leg	SAE 7,5 - 550013	135

Diagnosics

Finding the problem	Finding the possible cause	Possible solutions proposed
Fork doesn't get full travel	Oil level too high	Check oil levels
Fork doesn't get full travel	Spring rate too stiff	Change to softer spring rate
Fork doesn't get full travel	Spring rate too stiff	Decrease air pressure
Fork extends too quickly; harsh top-out after impacts	Rebound damping is not enough	Increase rebound damping
Fork extends too quickly; harsh top-out after impacts	Rebound damping is not enough	Replace the oil (SAE 7.5) with one of higher viscosity index
Fork has too much sag	Oil is too fluid	Check oil levels
Fork has too much sag	Spring rate too soft	Change to stiffer spring rate
Fork has too much sag	Spring rate too soft	Increase air pressure
Fork has too much sag	Spring rate too soft	Increase spring preload by replacing the preload tube
Fork is "sticky"; fork does not perform as new	Dirty sealing rings; fork needs to be serviced	Renew all seals
Fork is too soft, but the sag is the one recommended	Compression damping is not enough	Increase compression damping by changing oil volumes
Fork is too soft, needs more than the maximum preload	Oil is too fluid	Check oil levels
Fork is too soft, needs more than the maximum preload	Spring rate too soft	Change to stiffer spring rate
Fork is too soft, needs more than the maximum preload	Spring rate too soft	Increase air pressure
Fork stays down or "packs up" during multiple impacts	Rebound damping is too high	Decrease rebound damping with the relevant register
Front wheel tends to tuck under while turning left or right	Rebound damping is too high	Decrease rebound damping with the relevant register
Front wheel tends to tuck under while turning left or right	Spring rate too soft	Change to stiffer spring rate
Heavy amount of oil on stanchions; oil dripping down legs	Sealing rings damaged	Renew all seals
Heavy amount of oil on stanchions; oil dripping down legs	The stanchion tubes could be damaged	Have the stanchions be checked
Knocking sound during rebound, but no harsh top-out	Rebound damping is too high	Decrease rebound damping with the relevant register
Loss of sensitivity	Old oil	Change the oil
Loss of sensitivity	Sliding bushes worn	Renew the sliding bushes
Oil leaking from the bottom of the fork leg	Bottom nut/screw loose	Tighten the nut or screw
Oil ring on stanchions	Sealing rings dirty	Renew all seals